

PRODUCT INFORMATION PACKET

Model No: 182TTDBD6001

Catalog No: GT0012A

5 HP General Purpose Motor, 3 phase, 3600 RPM, 208-230/460 V, 182T Frame, ODP
Three Phase ODP Motors



Nameplate Specifications

Output HP	5 Hp	Output KW	3.7 kW
Frequency	60 Hz	Voltage	208-230/460 V
Current	14.0-13.2/6.6 A	Speed	3510 rpm
Service Factor	1.15	Phase	3
Efficiency	86.5 %	Power Factor	82
Duty	Continuous	Insulation Class	F
Design Code	A	KVA Code	K
Frame	182T	Enclosure	Drip Proof
Thermal Protection	No	Ambient Temperature	40 °C
Drive End Bearing Size	6206	Opp Drive End Bearing Size	6203
UL	Recognized	CSA	Y
CE	Y	IP Code	22

Technical Specifications

Electrical Type	Squirrel Cage Inverter Rated	Starting Method	Line Or Inverter
Poles	2	Rotation	Reversible
Resistance Main	4.05 Ohms	Mounting	Rigid Base
Motor Orientation	Horizontal	Drive End Bearing	Ball
Opp Drive End Bearing	Ball	Frame Material	Rolled Steel
Shaft Type	T	Overall Length	12.25 in
Frame Length	7.26 in	Shaft Diameter	1.125 in
Shaft Extension	2.75 in	Assembly/Box Mounting	F1/F2 CAPABLE
Connection Drawing	EE7308	Outline Drawing	SS600198-100

This is an uncontrolled document once printed or downloaded and is subject to change without notice. Date Created:07/01/2021

DASH NO.	4			3				2		1
	B	C	E	2E	2F	2FF	BA	BS	MOUNTING	
100	6.50	12.25	3.75	7.50	4.50	5.50	2.75	4.15	F1 OR F2	182T
200		13.25						5.15		184T

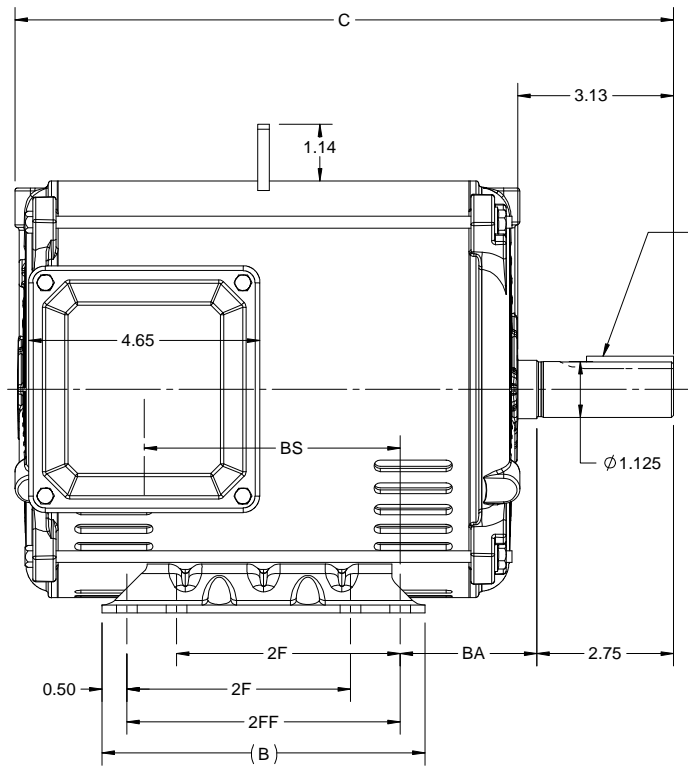

1/4 x 1/4 x 1.75 KEY

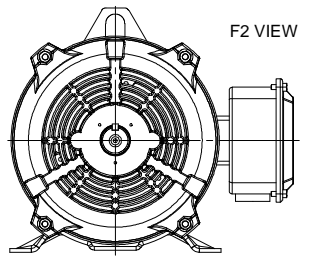
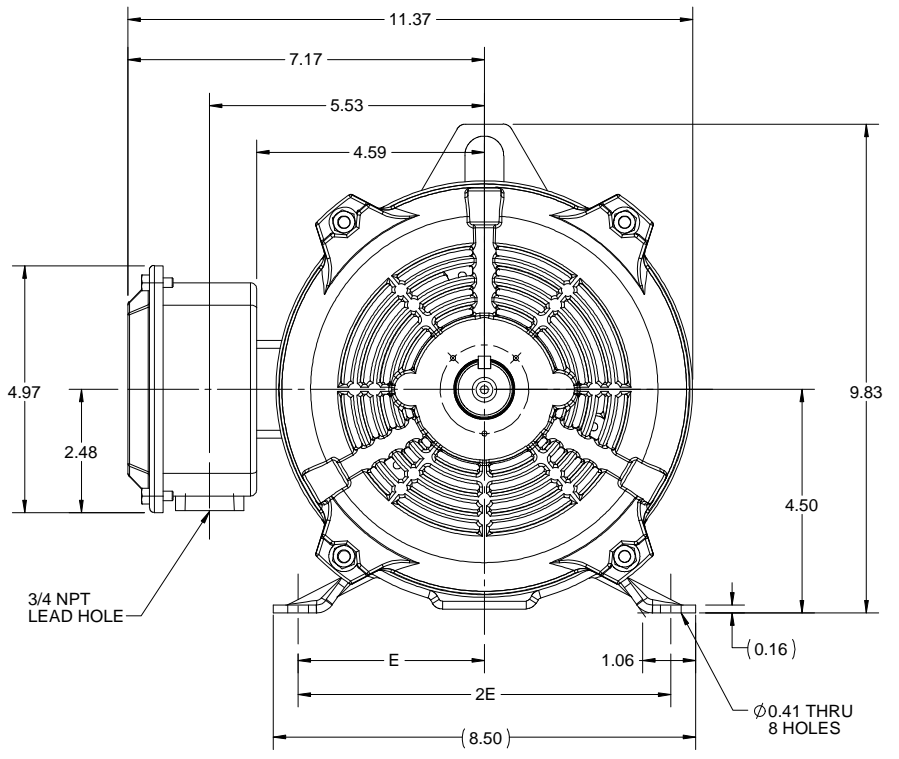

DRAWING REVISION E	REVISION BY ASHOK N	REV DATE/© DATE 19/11/2020
ECO ECO-0195163	APPROVED BY GNK	DATE 19/11/2020
ECO DESCRIPTION DRAWING UPDATED		
<small>COPYRIGHT (PER REVISION DATE) REGAL BELOIT AMERICA, INC. ALL RIGHTS RESERVED. PROPRIETARY AND CONFIDENTIAL INFORMATION - THIS DOCUMENT IS THE PROPERTY OF REGAL BELOIT AMERICA, INC. (OWNER) AND CONTAINS OWNER'S PROPRIETARY INFORMATION. ANY PERSON, CORPORATION OR OTHER FIRM RECEIVING IT IS DEEMED, BY RECEIVING IT, TO AGREE THAT IT, AND/OR ANY PART OF IT, SHALL NOT BE DISCLOSED TO ANY PERSON, CORPORATION OR OTHER ENTITY, DUPLICATED, AND/OR USED, EXCEPT AS EXPRESSLY APPROVED IN WRITING IN ADVANCE BY OWNER. THIS DOCUMENT SHALL BE RETURNED TO OWNER UPON REQUEST. IT MAY BE SUBJECT TO CERTAIN RESTRICTIONS UNDER APPLICABLE EXPORT CONTROL LAWS AND REGULATIONS.</small>		

PRIMARY DIMENSIONS ARE INCH
mm DIMENSIONS IN [BRACKETS]
ARE FOR REFERENCE ONLY

DRAWN BY PRIYA	 Regal Beloit America, Inc.
DATE 12/03/2018	
APPROVED BY SBD	DESCRIPTION OUTLINE 182/184T FR -NEMA-ODP RS
DATE 12/03/2018	MATERIAL
REFERENCE	PROCESS/FINISH
THIRD ANGLE PROJECTION	SIZE B
	DRAWING NUMBER SS600198
	SHEET 1 OF 1



NO.	REVISION	BY & DATE	CHK	ANG	TOLERANCES UNLESS SPECIFIED		FINISH	DRAWN RM 11/20/1990				
					DEC.	INCHES						
5	CHG TO REGAL LOGO	SL 09/10/2015	AB					CHK ML 11/21/1990				
4	REVISED IEC NOTATIONS	MSG 11/15/2011	CMN	.X	±.1			APPD SAS 04/24/2003				
3	ADDED IEC NOTATIONS... (U1), (V1) ETC. MU95194	MSG 5/10/2010	MJS	.XX	±.02		TITLE CONNECTION DIAGRAM	SCALE 1=1				
2	ADDED THE OPTIONAL CORD CONNECTION MU46318	RDH 04/24/2003	DRS	.XXX	±.005		3Ø - DUAL VOLTAGE MOTOR	REF				
1	REDRAWN	RM 11/20/1990		.XXXX	±.0005		MAT'L.	FMF				
					±7'30"			PREV				
THIS DRAWING IN DESIGN AND DETAIL IS OUR PROPERTY AND MUST NOT BE USED EXCEPT IN CONNECTION WITH OUR WORK ALL RIGHTS OF DESIGN AND INVENTION ARE RESERVED THIS IS AN ELECTRONICALLY GENERATED DOCUMENT - DO NOT SCALE THIS PRINT							RFP	CAD FILE ee7308	SIZE A	DRAWING NO. EE7308	PAGE OF 5	REV. 5
							DIST WP					



P.O. BOX 8003
WAUSAU, WI 54401-8003
PH. 715-675-3311

DATA VOLTS: 460

CERTIFICATION DATA SHEET

CUSTOMER: _____ **CUSTOMER P.O. #:** _____
ORDER #: _____ **REFERENCE MODEL #:** 182TTDBD6001
CONN. DIAGRAM: EE7308 **CAT #:** GT0012A
OUTLINE: SS600198 **CUSTOMER PART #:** _____
WINDING: HA31122024 NONE 2 **MOUNTING:** F1/F2 CAPABLE
SPEED: _____

TYPICAL MOTOR PERFORMANCE DATA

HP	KW	SYNC RPM	FL RPM	FRAME	ENCLOSURE	TYPE	KVA CODE	DESIGN
5	3.7	3600	3510	182T	DP	TDB	K	A

PH	HZ	VOLTS	AMPS	START TYPE	DUTY	INSL	S.F.	AMB	ELEV.
3	60/50	208-230/460#190/380	14-13.2/6.6&10/5	LINE OR INVERTER	CONT	F	1.15	40	3300

F.L. EFF	86.5	3/4 LD EFF	86.5	1/2 LD EFF	84.0	GTD EFF	ELECT. TYPE
F.L. PF	82.0	3/4 LD PF	74.0	1/2 LD PF	61.0	85.5	SQ CAGE INV RATED

F.L. TORQUE	LR AMPS @ 460 V	L.R. TORQUE	B.D. TORQUE	F.L. RISE (° C)
7.5 LB-FT	50.0	13.0 LB-FT 173%	22.0 LB-FT 293%	55

SOUND PRESSURE	SOUND	ROTOR WK ²	MAX. LOAD WK ²	SAFE STALL TIME	STARTS/HOUR	APROX.
55 dBA	64 dBA	0.20 LB-FT ²	10 LB-FT ²	10 SEC.	2	58 LB.

***** SUPPLEMENTAL INFORMATION *****

DE BRACKET TYPE	ODE BRACKET TYPE	MOUNT TYPE	MOTOR ORIENTATION	SEVERE DUTY	HAZARDOUS LOCATION	DRIP COVER	SCREENS	PAINT
STANDARD	STANDARD	RIGID	HORIZONTAL	NO	NONE	YES	NONE	BLUE (ENAMEL)

BEARINGS		GREASE	SHAFT TYPE	SPECIAL DE	SPECIAL ODE	SHAFT MATERIAL	FRAME MATERIAL
DE	ODE	POLYREX EM	T	NONE	NONE	1045 HOT ROLLED (C-204)	ROLLED STEEL
BALL	BALL						
6206	6203						

THERMOSTATS	PROTECTORS	WDG RTD's	BRG RTD's	THERMISTORS	CONTROL	SPACE HEATERS
NONE	NOT	NONE	NONE	NONE	FALSE	NA

R1 (ohms/ph)	R2 (ohms/ph)	X1 (ohms/ph)	X2 (ohms/ph)	Xm (ohms/ph)	VIBRATION (in/sec)	FLOAT
2.211	1.049	4.394	1.361	76.772	0.150	ODE

* N O T E S *	INVERTER TORQUE: CONSTANT 2:1/VARIABLE 10:1	
	INV. HP SPEED RANGE: NONE	
	ENCODER: NONE	
	NONE NONE NONE PPR	

PREPARED BY:	DATE: 7/20/2020	BRAKE: NONE	NONE NONE
		FT-LB: NA	
		VOLTAGE: NONE	HZ:
FORM: 3531 REV_4 2/27/06		UL: V - L,ME-INS,CONST UL REC	

